

ALUKAP[®]-SS

High-Spanning Glazing System Technical Guide

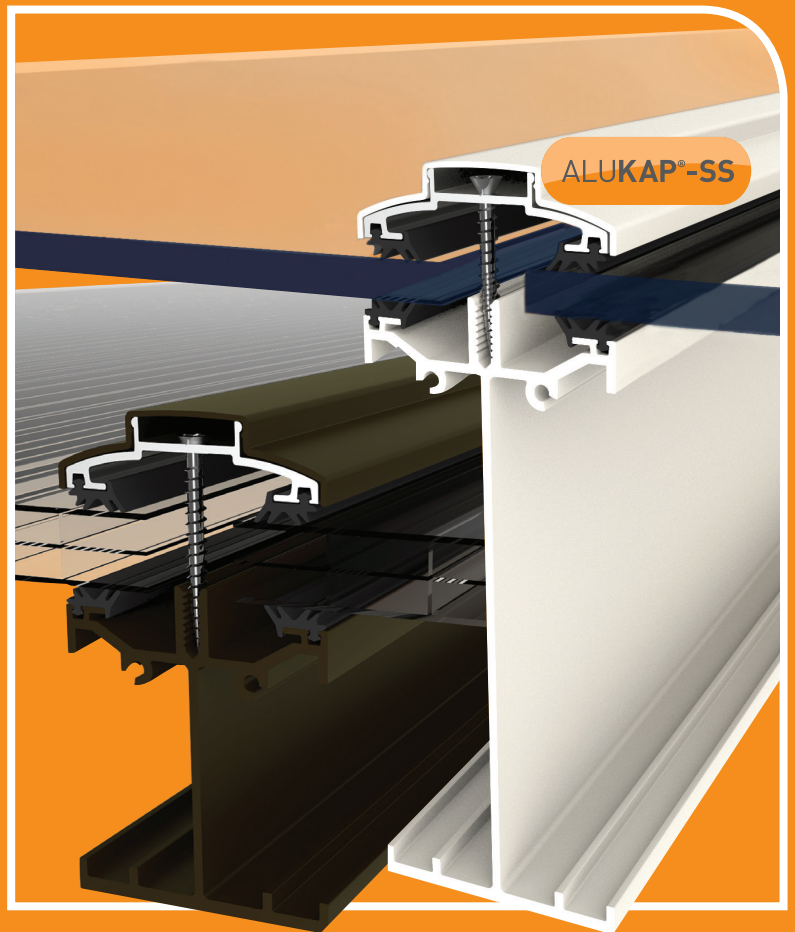

High-Span Glazing Solution

ALUKAP®-SS self-support system has been designed to combine exceptional strength ratios with an excellent and aesthetically pleasing finish.

The simplicity of ALUKAP®-SS reduces installation time without reducing the quality of the finished product. Manufactured almost entirely from aluminium extrusion the ALUKAP®-SS system provides an integrated low-weight high-strength structure.

ALUKAP®-SS accommodates AXIOME® multiwall sheet in almost any thickness including 6mm, 10mm, 16mm, 25mm and 35mm. Additionally the high strength design of ALUKAP®-SS is perfectly suited to single glass and double glazed glass units options of almost any thickness.



Common uses:

- ✓ Decking and Veranda Covers
- ✓ Covered Walkways
- ✓ Carports
- ✓ Shelters
- ✓ Play Area Covers
- ✓ Conservatories
- ✓ Swimming Pools
- ✓ Lean To's

Qualities:

- ✓ Excellent Spanning Capabilities
- ✓ No need for Timber Rafters
- ✓ Fast to Install
- ✓ All Powder-Coated Aluminium for Longevity
- ✓ Maintenance Free
- ✓ Suited to Single Glass, Double Glazed Units and AXIOME® Multiwall



ALUKAP®-SS : Low Profile Bar

The ALUKAP®-SS Low Profile glazing bar system offers a spanning range of between three and four meters depending on chosen loading ratings and choice of glazing material. This is ideal for shorter spans, and also areas where a centre purlin is provided to break the overall span, and provides a perfect solution where project budgets are limited.

This ALUKAP®-SS Low Profile bar is suited to almost any glass or AXIOME® multiwall thickness.

Wall and Gable bar options are readily available to provide a suitable finish to the upper part of the glazing beams at wall abutments and gable ends.

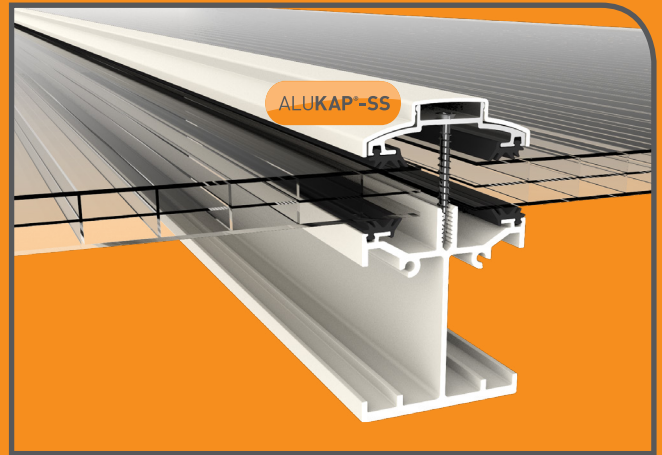

ALUKAP®-SS : Low Profile Wall Bar

The ALUKAP®-SS Low Profile Wall Bar provides a perfect finish where the glazing abuts a rising wall. The integral upstand provides an excellent waterproof connection for lead flashing or flash band to drop down over. This also reduces installation time on site and provides a lasting leak-proof solution.



ALUKAP®-SS : Low Profile Gable Bar

The ALUKAP®-SS Low Profile Gable Bar provides a perfect finish to the end bar of ALUKAP®-SS glazing. The simplicity of the down stand means that it works with any thickness of glazing.



ALUKAP®-SS : High Span Bar

This High Span ALUKAP®-SS bar outperforms possibly every other bar on the market when it comes to self-supported spanning distances.

With a free-spanning capability between five and six meters this ALUKAP®-SS High Span bar system can be used to create much more usable spaces with less posts and other supports required.

From barbecue covered decking areas, to double-width carports and children's play areas this beam creates a space to suit a wide range of commercial, public and residential structures.

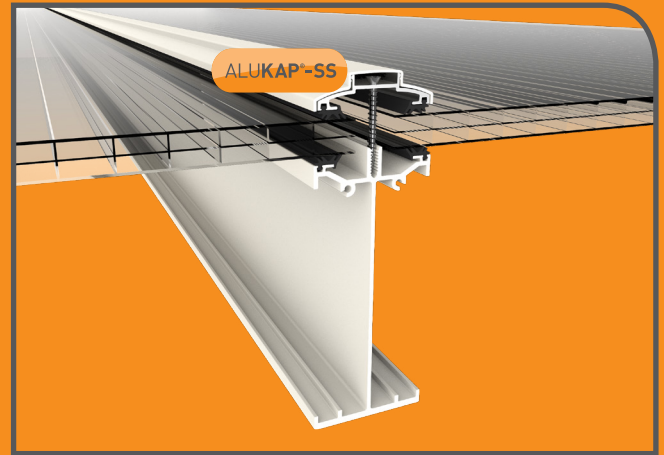

ALUKAP®-SS : High Profile Wall Bar

The ALUKAP®-SS High Span Wall Bar provides a perfect finish where the glazing abuts a rising wall. The integral upstand provides an excellent waterproof connection for lead flashing or flash band to drop down over. This also reduces installation time on site and provides a lasting leak-proof solution.



ALUKAP®-SS : High Profile Gable Bar

The ALUKAP®-SS High Span Gable Bar provides a perfect finish to the end bar of ALUKAP®-SS glazing. The simplicity of the down stand means that it works with any thickness of glazing.



ALUKAP®-SS : Wall Plate

Using the same profile as the ALUKAP®-SS Eaves Beam, the ALUKAP®-SS Wall Plate can be bolted to a wall or similar structure to provide a robust and straight wall plate to glaze from.

The ALUKAP®-SS Wall Plate is designed to work with glazing pitches from 2.5 to 25 degrees.

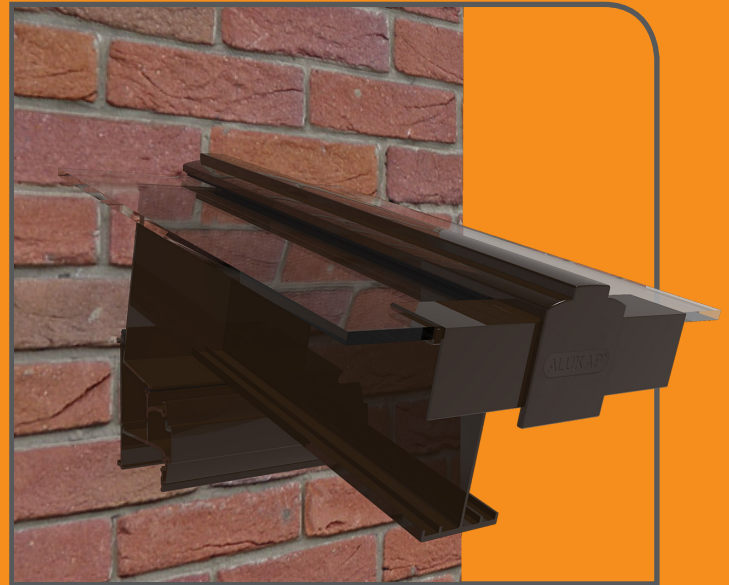
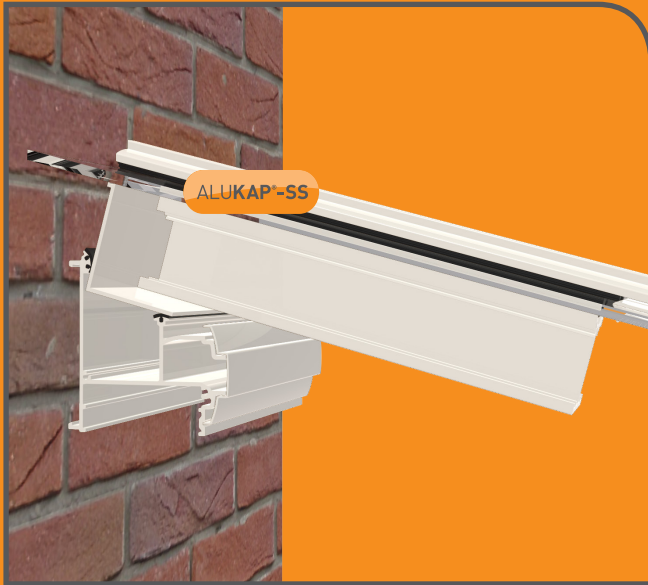

ALUKAP®-SS : L-Cap Bar

As with the Eaves Beam the ALUKAP®-SS Wall Plate has an optional ALUKAP®-SS L-Cap for structures where draft and wind proofing are essential.

'L-Cap' High Span Bar



'L-Cap' Low Profile Bar



ALUKAP®-SS : Eaves Beam

The ALUKAP®-SS Eaves Beam provides a variable pitch solution to suit a wide range of required pitches. Manufactured using high quality powder-coated aluminium profiles this beam is designed with strength, aesthetics and longevity in mind.

The intersecting ALUKAP®-SS bars simply bolt in to the ALUKAP®-SS Eaves Beam with M6 stainless steel bolts provided, and the cover strip clicks in to place concealing the fixing points. The ALUKAP®-SS Eaves Beam also provides an installer-friendly Deep Flow QUADRAFLO® Gutter bracket locator to increase speed and accuracy during installation.

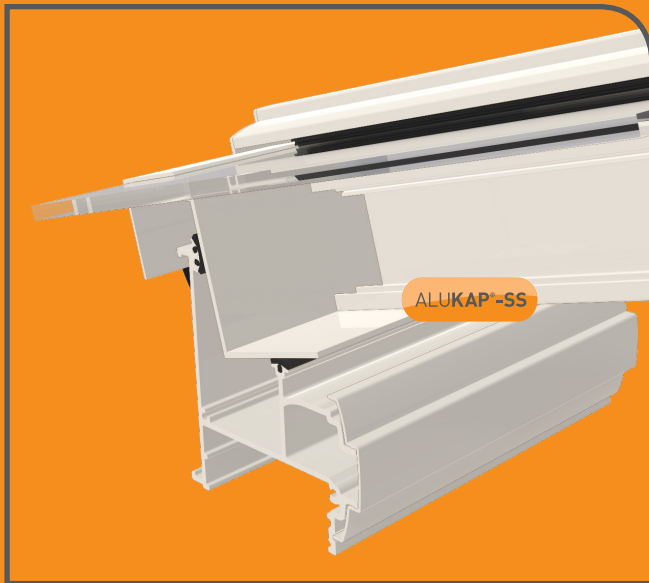

ALUKAP®-SS : L-Cap Bar

There is an optional ALUKAP®-SS L-Cap for structures where draft and wind proofing are essential, however where the structure is open there is a cost saving to be made by omitting the ALUKAP®-SS L-Cap.

'L-Cap' High Span Bar



'L-Cap' Low Span Bar



ALUKAP®-SS : NEW Improved Posts

The ALUKAP®-SS NEW improved post system provide enhanced strength. The four-pronged brackets are bolted to a strong and firm base and the posts slots inside. Similarly the upper bracket is bolted to the underside of the ALUKAP®-SS Eaves Beam / Wall Plate, which then slots in to the top of the ALUKAP®-SS Post. A bolt is secured through the post, securing the brackets to the post from uplift. The nut and the head of the bolt should be fixed through the side of the post, so that they are concealed within the recessed side channels.



NEW

ALUKAP®-SS : Wall Plate and Eaves Beam Deductions

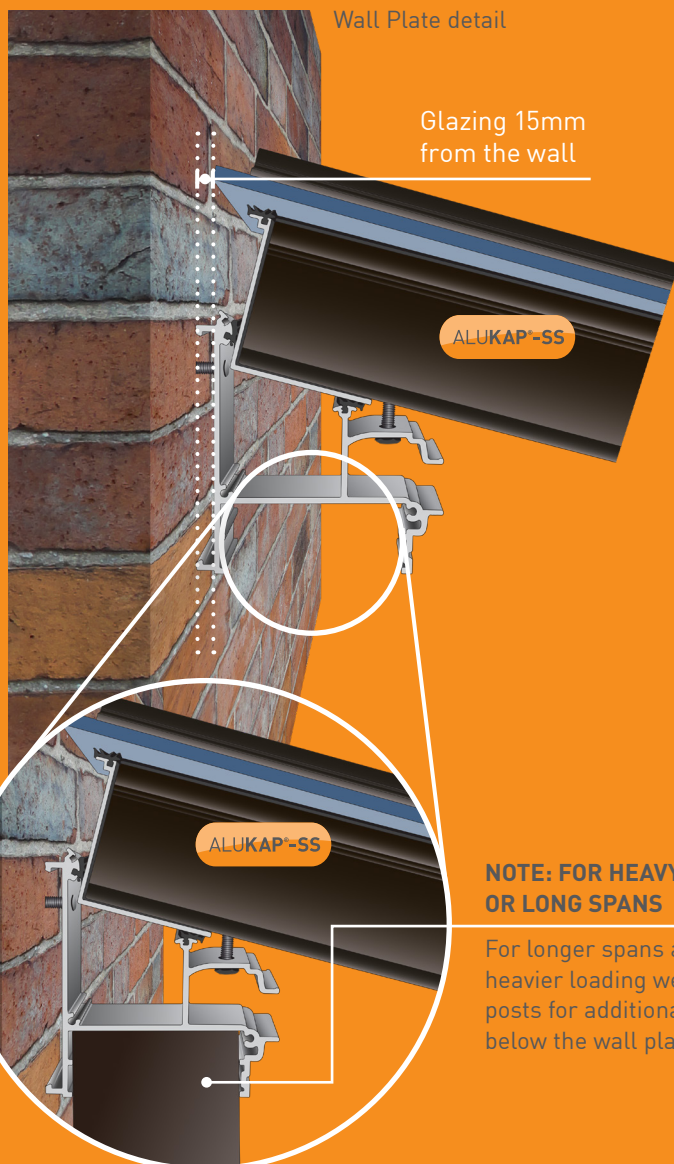

At the ALUKAP®-SS Wall Plate end, deduct 15mm from the top end of the glazing material to allow for expansion and contraction. The lead flashing from the wall should then come down and dress over this. On lower pitched roofs the flashing should be sealed on to the glazing with a compatible sealant in order to prevent water ingress in severe weather.

At the ALUKAP®-SS Eaves Beam end of the ALUKAP®-SS roof, you should ensure that the glazing extends beyond the face of the ALUKAP®-SS Eaves Beam by 30mm to allow the water to run off the roof in to the gutter.



NOTE: FOR HEAVY LOADS OR LONG SPANS

For longer spans and / or heavier loading we recommend posts for additional support below the wall plate also.

Inasmuch as Clear Amber have no control over the circumstances in which our material may be used, or site specific parameters, we cannot guarantee that any particular results will be achieved. Users should carry out their own tests to determine the suitability of the material for their application. Installers should satisfy themselves that published permissible loadings and bar spacings for ALUKAP®-SS structures, together with any supporting posts, frames, or walls and fixings, are sufficient to provide adequate strength for the intended use and to meet regional loading requirements. Installers should also obtain their own job-specific structural engineer's report for their individual site. Samples are readily available to users to test and verify the exact sizes according to their site requirements.

ALUKAP®-SS : Glazing Deductions

Glazing deduction guidelines are shown below for the ALUKAP®-SS bar system for ALUKAP®-SS Wall bars, ALUKAP®-SS standard/centre bars and ALUKAP®-SS Gable bars however, these may need to be amended depending on chosen glazing materials and glazing centres. Samples are readily available to users to test and verify the exact sizes according to their site requirements.

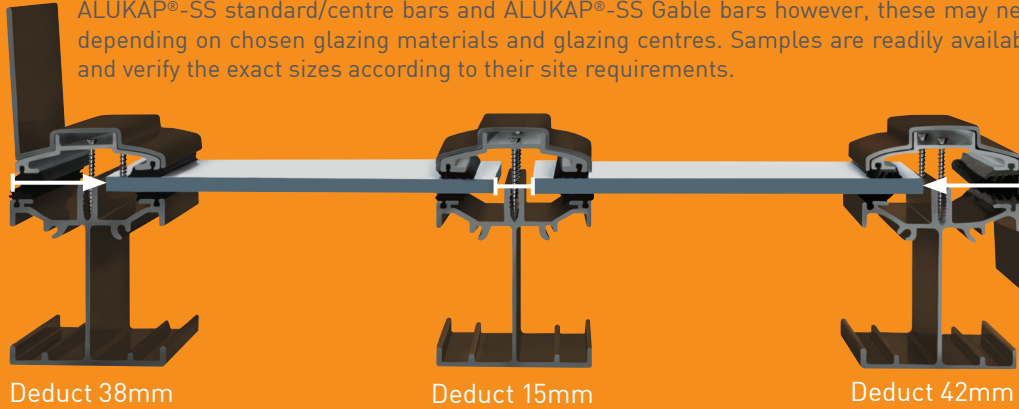

ALUKAP®-SS : Suited to any Thickness or Type of Glazing

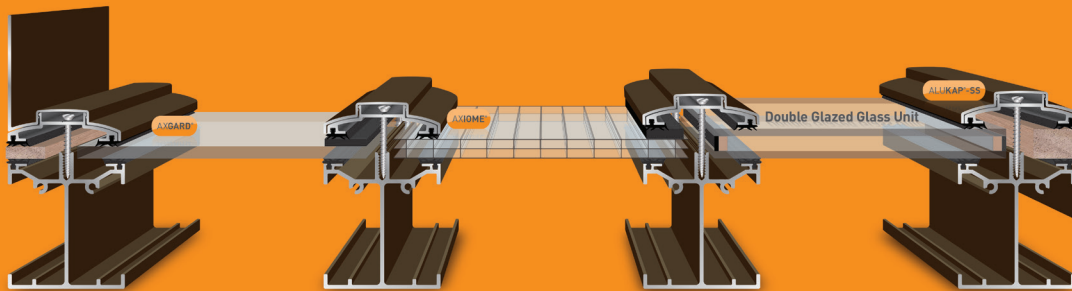

ALUKAP®-SS : Typical Roof Component Assembly Example

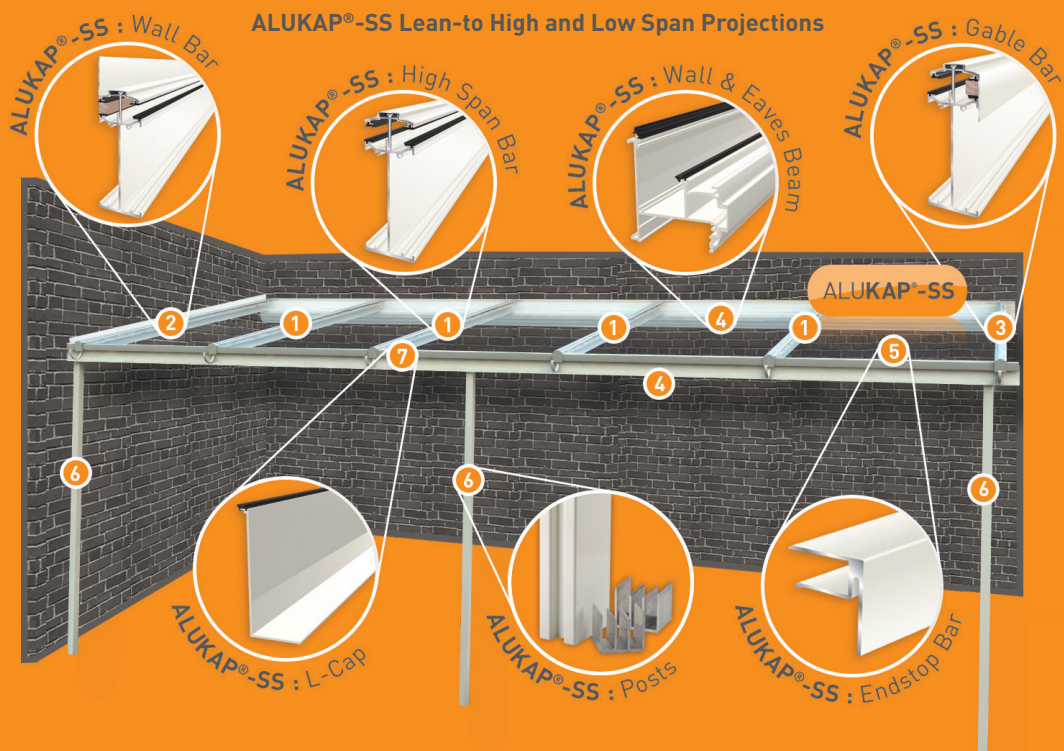

ALUKAP®-SS : Spanning

The following ALUKAP®-SS Spanning guides have been calculated by independent structural engineers and provide an excellent resource for specifying correct spans and bars specification depending of the estimated wind and snow loading requirements for the specific location. *NOTE: loads are unfactored (i.e. do not include partial safety factors of 1.2 for wind or 1.33 for imposed).*

These ALUKAP®-SS Spanning guides show the deflection of the bars at three given loads per linear metre for several different length options. There is a set for the three most common glazing options for both the ALUKAP®-SS Low Profile bar and also the ALUKAP®-SS High Span bar. Notwithstanding separate glazing sheet limitations these figures are the expected results when the bars are spaced at 1000mm centres, where force on one linear meter of bar equates to the same force for one square meter of structure.

For most glazing sheets 1000mm width centres is normally too wide, however from these figures you can simply calculate your desired width and then check the width. For example, for a roof requiring 0.6kN of load, but where the ALUKAP®-SS bars are set at 700mm centres, you can take the 0.6kN load and divide by 1000mm width, then multiply back up by 700mm width and you will find the effective force on the actual ALUKAP®-SS bar is reduced to 0.42kN per linear meter: $0.6 / 1000 \times 700 = 0.42$. Therefore by reducing the glazing centres some incredible free span distances can be achieved.

Samples are available to users to test and verify the exact sizes according to their site requirements, and users should not rely on the data below, but have a site specific structural report created taking in to consideration all variants.

ALUKAP®-SS Spanning with AXIOME®

ALUKAP®-SS Low Profile Bar with AXIOME®

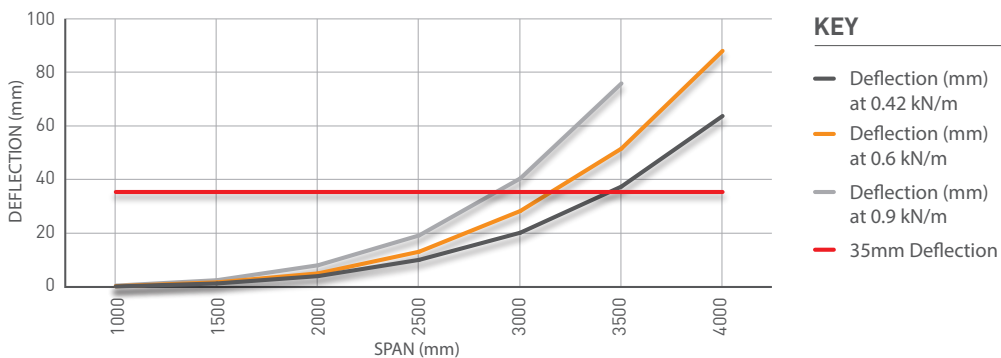

AXIOME® glazing sheets are the lightest weight option and allow the highest spanning distances. These charts provide a guide of spanning that can be achieved for the ALUKAP®-SS Low Profile and ALUKAP®-SS High Profile bars using any thickness of AXIOME® glazing sheets. You also need to check what spanning the chosen AXIOME® sheets can achieve themselves in conjunction with this data.

ALUKAP®-SS High Span with AXIOME®

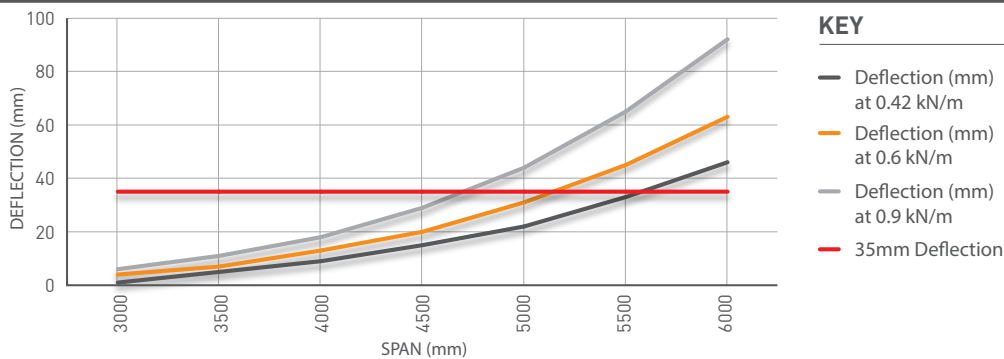

ALUKAP®-SS Spanning with 4mm Double Glazing

4mm Glass units are a common option for glazing and these charts provide a guide of spanning that can be achieved for the ALUKAP®-SS Low Profile and ALUKAP®-SS High Profile bars. You also need to check with your glass supplier what spanning glass units can achieve in conjunction with this data.

ALUKAP®-SS Low Profile Bar with 4mm Double Glazing

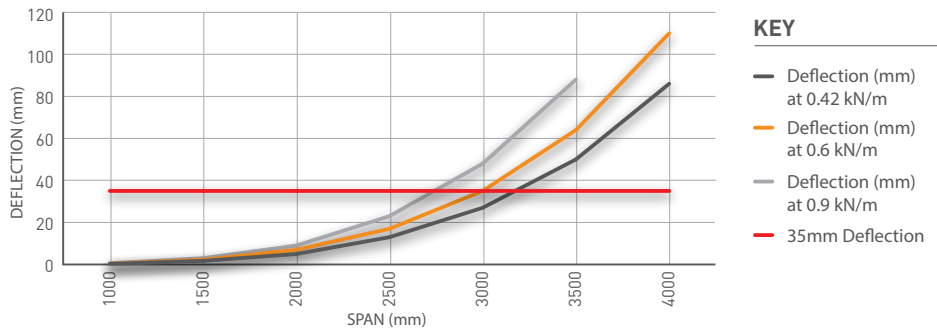

ALUKAP®-SS High Span with 4mm Double Glazing

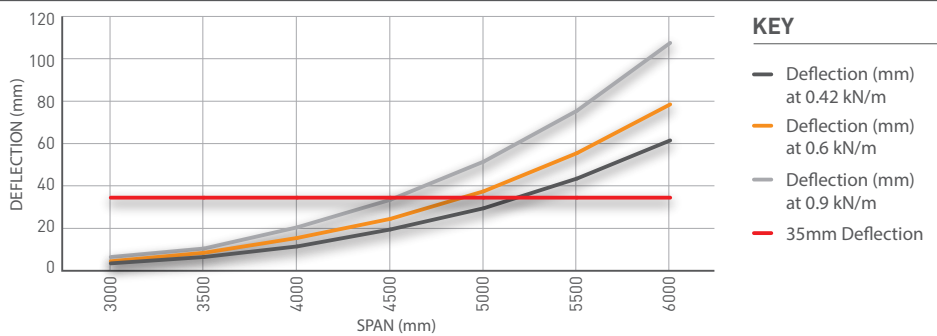

ALUKAP®-SS Spanning with 6mm Double Glazing

Using 6mm Glass units is the most challenging due to the extra weight. These charts provide a guide of spanning that can be achieved for the ALUKAP®-SS Low Profile and ALUKAP®-SS High Profile bars with 6mm double glazed sealed units. You also need to check with your glass supplier what spanning glass units can achieve in conjunction with this data.

ALUKAP®-SS Low Profile Bar with 6mm Double Glazing

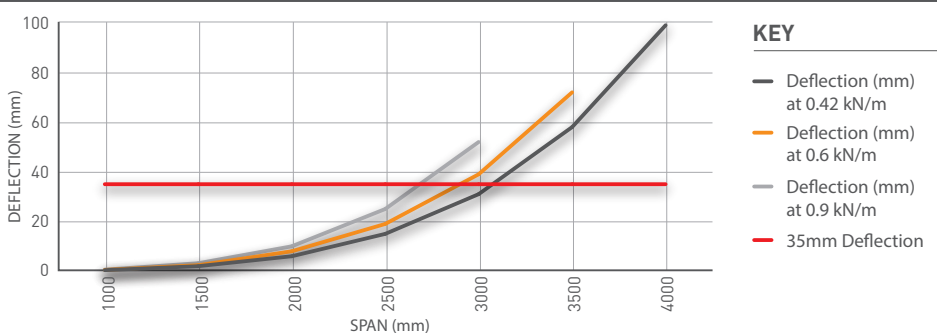

ALUKAP®-SS High Span with 6mm Double Glazing

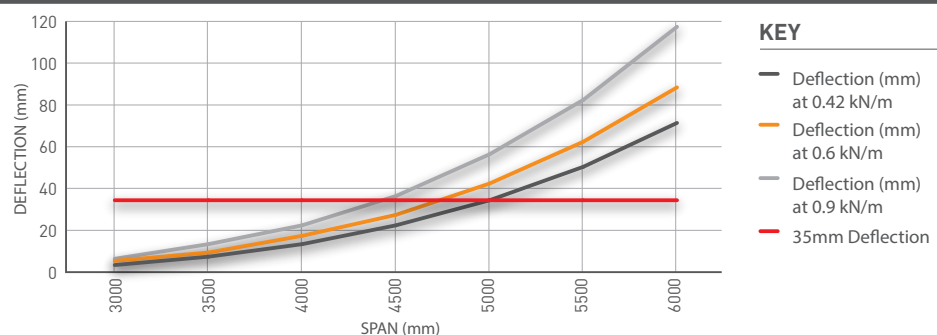

ALUKAP®-SS : Eaves Beam Post Spacing

As always you should always consult a structural engineer and make sure you have your structure correctly set up depending on the location, exposure, pitch and several other site-specific factors. However we have set out some calculated figures to provide a rough guide of spacing between ALUKAP®-SS posts. For larger constructions, ALUKAP®-SS roofs can be further strengthened by many bespoke additions such as bracing, gallows brackets etc.

ALUKAP®-SS Eavesbeam Calculations

Max Distance Between Posts	Total Load: 0.6kN/m ²	Total Load: 0.9kN/m ²	Total Load: 1.2kN/m ²
3m Projection	2.80m	2.47m	2.42m
4.8m Projection	2.42m	2.10m	1.80m
6.0m Projection	2.25m	1.85m	1.60m

ALUKAP®-SS Disclaimer: These calculations are carried out in accordance with BS 8118 but are intended as a guide only. Inasmuch as Clear Amber have no control over the circumstances in which our material may be used, we can-not guarantee that any particular results will be achieved. Users should carry out their own tests and obtain structural engineer calculations as required to determine the suitability of the material for their application. Installers should satisfy themselves that published permissible loadings and bar spacing's for ALUKAP®-SS roofs and posts are sufficient to provide adequate strength for the intended use and to meet regional loading requirements.

Example diagram showing dimensions of an ALUKAP®-SS Glazing System

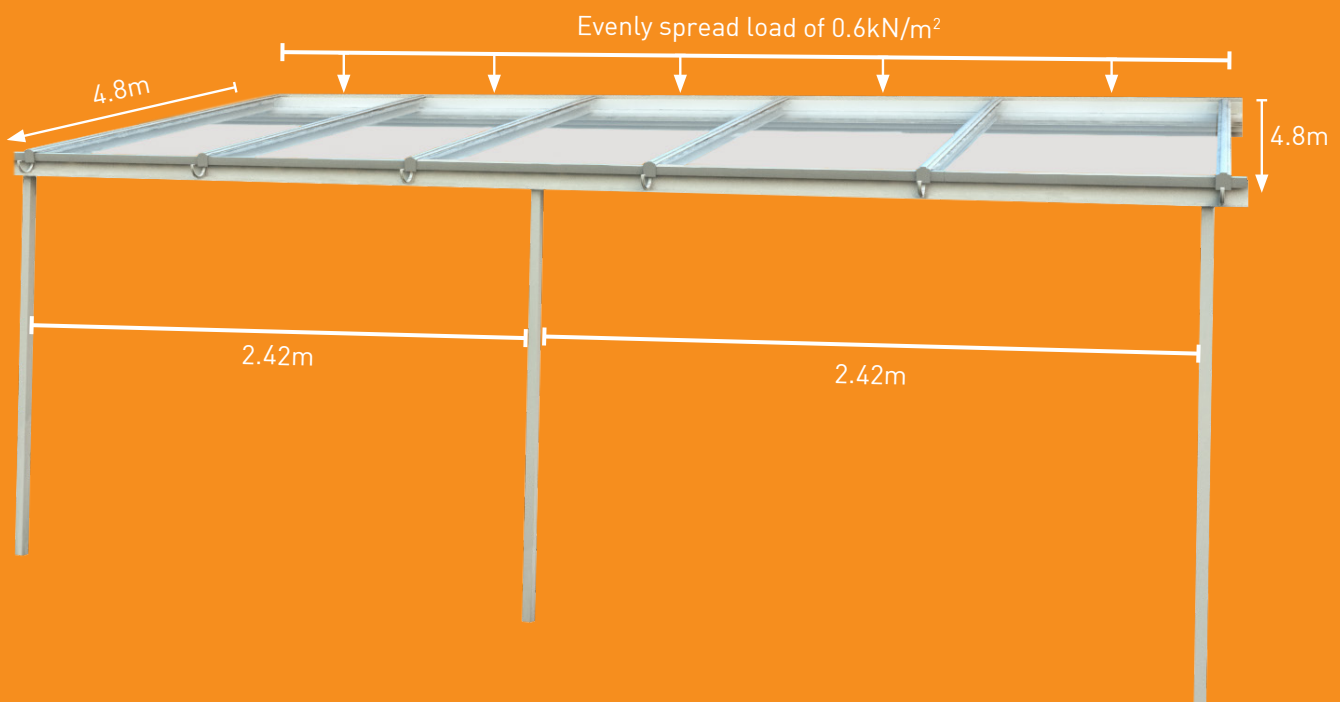

ALUKAP®-SS : Heritage Range

This standard palette of colours are designed to provide a core range of most popular colours that are frequently requested. By collating this suite of hues we are able to provide faster deliveries for your day-to-day requirements whilst still meeting the demands for a wider choice of matching profiles.



Other Bespoke Colours:

ALUKAP®-SS can be coloured to any RAL code, using our special coating process.

RAL 9010 ALUKAP® White	RAL 1011 Brown Beige	RAL 3003 Ruby Red	RAL 3005 Wine Red	RAL 5007 Brilliant Blue	RAL 5011 Steel Blue
RAL 6021 Pale Green	RAL 6005 Moss Green	RAL 6009 Fir Green	RAL 7035 Light Grey	RAL 7038 Agate Grey	RAL 7040 Window Grey
RAL 7005 Mouse Grey	RAL 7011 Iron Grey	RAL 7016 Anthracite Grey	RAL 8016 Mahogany Brown	RAL 8017 Chocolate Brown	RAL 8040 ALUKAP® Brown

WARNING : REGISTERED DESIGNS & PATENTS

The IP of the designs in this brochure are protected by internationally registered design rights. Many products are also protected with active or pending Patents. Clear Amber will not hesitate to take appropriate legal action if its rights in this respect are infringed.

© Copyright – Clear Amber Group Ltd – August 2019. No part of this publication may be copied, reproduced, scanned, or stored in any electronic database, whether in whole or in part, in any form or by any means, without permission in writing from Clear Amber. Clear Amber will not hesitate to take appropriate legal action if its rights in this respect are infringed.

Inasmuch as Clear Amber have no control over the circumstances in which our material may be used, or site specific parameters, we cannot guarantee that any particular results will be achieved. Users should carry out their own tests to determine the suitability of the material for their application. Installers should satisfy themselves that published permissible loadings and bar spacings for ALUKAP®-SS structures, together with any supporting posts, frames, or walls and fixings, are sufficient to provide adequate strength for the intended use and to meet regional loading requirements. Installers should also obtain their own job-specific structural engineer's report for their individual site. Samples are readily available to users to test and verify the exact sizes according to their site requirements.